

RAGNAR HYDR 5-24 (1125-7015)



Control type
konventionell

Construction year
NEU

Machine no.
1125-7015

Make
RAGNAR

Location
D - 49779 Niederlangen

Machine attributes

thread dia.:	M5 - M24 mm
threading length:	-- mm
thread pitch:	-- mm
turning speeds:	0-600 / 0-150 U/min
table surface area:	700 x 900 mm
work height max.:	900 mm
working area:	2050 Rmax. mm
working area:	500 Rmin. mm
total power requirement:	3,0 kW
weight of the machine ca.:	300 kg

Machine images

© Heinz Sanders GmbH

ARM OPERATING MEASUREMENTS

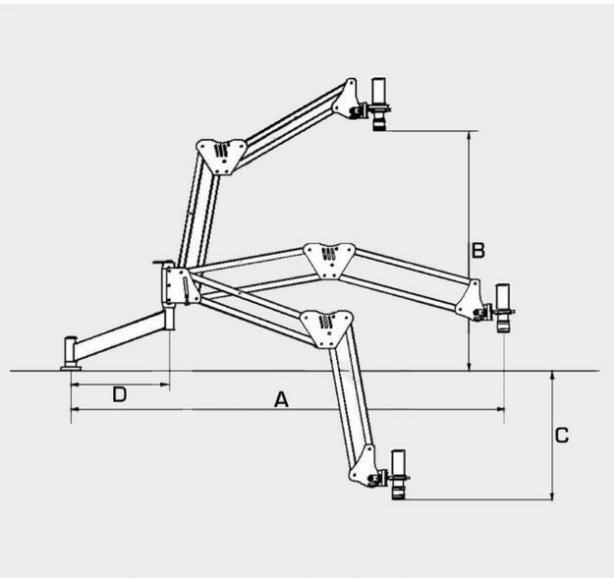

MODEL	A	B	C	D
RAGTAP M5 - M24	2050	920	700	500